

**Product information**

**Pressure Switch PH1**



- Adjustable switch point
- Adjustable hysteresis
- Change over contact
- Plug DIN 43650-A
- Lateral cable exit

**Characteristics**

Mechanical pressure controller in which a membrane or piston is pre tensioned by a spring. Two adjustment screws permits the setting of the switch point and the hysteresis.

**Technische Daten**

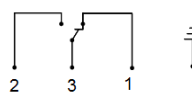
<b>Switch</b>	Mechanical switch	
<b>Process connection</b>	Male thread R1/4, G1/8, G1/4, 1/4NPT, 1/8NPT, M10x1	
<b>Switching range</b>	0,2..320 bar	for details see table "Ranges"
<b>Pressure resistance</b>	PS 60bar/ 350 bar	
<b>Tolerance</b>	± 2% at RT relative to full scale value	
<b>Hysteresis</b>	Adjustable, see diagram „Hysteresis“	
<b>Media temperature</b>	-20..+80°C (Viton 0..100°C)	
<b>Ambient temperature</b>	-20..+80°C	
<b>Media</b>	water, oils, gases	
<b>Wiring</b>	Change over No. 0.467 	
<b>Switching voltage</b>	Max. 250 VAC	
<b>Switching current</b>	Max. 4 A (2 A inductive)	
<b>Protection class</b>	1 – PE connection	
<b>Ingress protection</b>	IP 65	
<b>Electrical connection</b>	Plug DIN 43650-A/ ISO 4400 with screw clamp in the plug	
<b>Materials medium-contact</b>	Diaphragm type NBR or EPDM or Viton. Piston type: PTFE with NBR or EPDM or Viton steel, zinc coated or stainless steel (1.4305)	
<b>Non-medium-contact materials</b>	PA 6.6, NBR	
<b>Weight</b>	0,15kg	
<b>Installation location</b>	installation location as desired	

**Ranges**

Switching Range bar (rel.)	Type	Pressure resistance PS bar	Functional principle
- 0,85 ..1	001	60	Diaphragm
0,2 .. 2	002		
0,5 .. 8	008		
1 .. 16	016		
10 .. 30	030		
10 .. 80	080	350	Piston
10 .. 120	120		
10 .. 160	160		
20 .. 200	200		
20 .. 250	250		
30 .. 320	320		

**Dimensions**

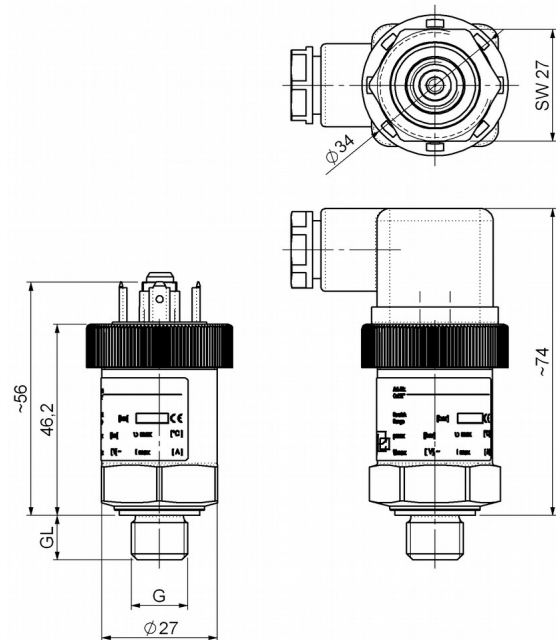

**Handling and operation**

**Notes**

- If the medium is dirty, install a filter
- It must be ensured that the values given for voltage, current, and power are not exceeded.
- Check resistance to aggressive media, no DI water.
- Supplied with mating plug.

Torques and thread lengths of the fluid connections  
 R 1/4, G 1/4, 1/4NPT    20-25 Nm    12 mm  
 G 1/8, 1/8NPT, M10x1    15-20 Nm    10 mm

**Product information**

**Adjustment**

- Loosen the plug and set the desired switching value using a hex wrench (size 2, screw centered). Then adjust the hysteresis using a longitudinal slot screwdriver 2,5x0,4 (screw laterally). Turn to right increases the value. Then attach the plug back onto the device and tighten the screw.

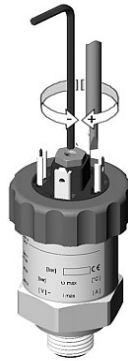

**Hysteresis**

The diagram indicates possible adjustments of the hysteresis in relation to the switch point (idealized representation). Thus, for example for the piston type at a switch point 130 bar, it can be set a hysteresis between 20 bar and 32 bar.

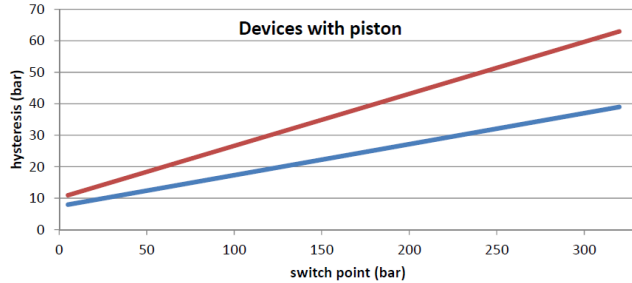
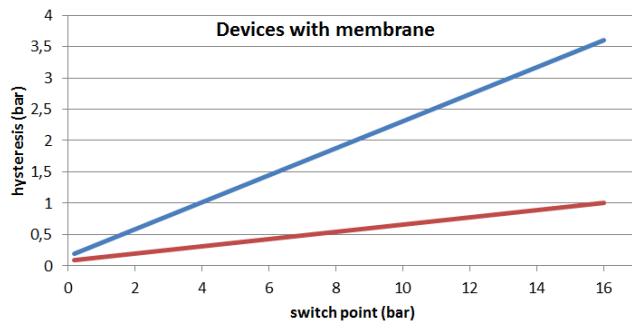

**Ordering code**

PH1 - 1.  2.  3.  4.  5.  6.   
 PH1 -

<b>1. Switching range</b>	
001	- 0,85 .. 1 bar
002	0,2 .. 2 bar
008	0,5 .. 8 bar
016	1 .. 16 bar
030	10 .. 30 bar
080	10 .. 80 bar
120	10 .. 120 bar
160	10 .. 160 bar
200	20 .. 200 bar
250	20 .. 250 bar
320	30 .. 320 bar
<b>2. Connection material</b>	
K	Stainless steel
S	Steel, zinc coated
<b>3. Connection size</b>	
004A	G 1/8A
008H	R 1/4
008A	G 1/4A
009H	NPT1/8 no stainless steel
011A	M10x1 no stainless steel
012H	NPT1/4
<b>4. Rotatable</b>	
0	Fixed
<b>5. Electrical connection</b>	
B	Plug DIN 43650-A
<b>6. Sealing / diaphragm</b>	
N	NBR
E	EPDM
V	Viton

**Options**

- Factory setting of the switch point and hysteresis on falling or rising pressure.